

LIFE P04 HIGH EFFICIENCY BATTERY



AVAILABLE MODELS 12-24-48V

1. Scope

This specification only applies to the reference battery in this specification and manufactured by SHENZHEN CERROPOWER CO.LTD.

2. Rating

	Item	Rating	Note
Cell	Type	LiFePO4 Battery	
	Cell Model	LF26700-4.0A	
	Nominal Capacity	4.05Ah	Discharge : 0.2C Cut-off Voltage: 2.5V
	Minimum Capacity	4.0Ah	Discharge : 0.2C Cut-off Voltage: 2.5V
	Nominal voltage	3.2V	
	Internal Impedance	≤30mΩ	
	Dimension	MAX. 26.8*70.5mm	
	Weight	95g	
Battery pack	Pack Method	8S3P	
	Nominal Capacity	12.1Ah	Discharge : 0.2C Cut-off Voltage:20V
	Minimum Capacity	12Ah	Discharge : 0.2C Cut-off Voltage: 20V
	Nominal Voltage	25.6V	
	Energy	307.20Wh	
	Charge Voltage	29.2V	
	Discharge cut-off voltage	20V	
	Charge Method	CC/CV	
	Standard Charge Current	2.4A	
	Max. Charge Current	12.0 A	
	Standard Discharge Current	2.40A	
	Max. Continues Discharge current	36A	
	Cycle Life	2000 times	≥80%
	Internal Impedance	≤90mΩ	
	Case Dimension	165*125*175mm ± 3mm	
	Output Wire		
	Output Connector	F2 Terminal	
Weight	Approx.2.30 Kg		
Working Temperature Range	Charge: 0°C--45°C Discharge: -20°C--60°C		

	Storage Temperature	-10°C--45°C	
--	---------------------	-------------	--

3. Protection Circuit

3.1 BMS Parameter

No.	Item	Standard	
1	Charge Current	≤25A	
2	Discharge Current	≤25A	
3	Overcharge	Over-Charge Detect Voltage	3.65±0.025 V
		Over-Charge Delay Time	0.7~2.0 S
		Over-Charge Reset Voltage	3.55±0.05 V
4	Over-discharge	Over-Discharge Detect Voltage	2.5±0.01 V
		Over-Discharge Delay Time	1-3S
		Over-Discharge Reset Voltage	2.3±0.10 V
5	Over-current	Over-Current Detect Current	75 A
		Over-Current Delay Time	500 ms
		Reset	Release load
6	Short Circuit	Detect Status	External Short Circuit
		Delay Time	150~540 us
		Reset	Release load
7	Thermal Switch	75±5°C	
8	Resistance	≤30mΩ	

3.2 Circuit diagram:

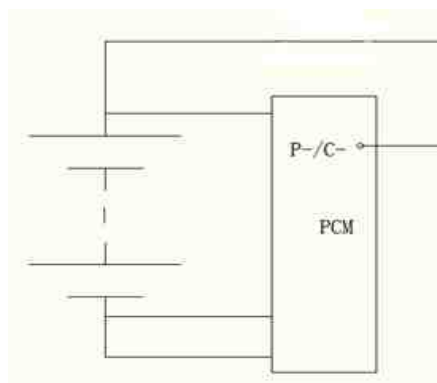

4. Appearance

It shall be free from any defects such as remarkable scratches, breaks, cracks, discoloration, leakage, or

deformation, and it shall be clean and have equality and product value.

5. Performance

5.1 Standard Test Condition

The battery shall be evaluated within 1 month from the arrival date.

Unless otherwise stated in these specifications, the following test shall be carried out in an ambient temperature of $20\pm 5^{\circ}\text{C}$, relative humidity of $65\pm 20\%$

Discharge capacity when the battery is discharged at 2.4A to 20V after being standard charged. Five cycles are permitted for this test. The test shall be terminated at the end of the first cycle which meets the requirement.

5.2 Testing Instrument or Apparatus

5.2.1 Dimension Measuring Instrument

The dimension measurement shall be implemented by instruments with equal or more precision scale of 0.01mm specified.

5.2.2 Voltmeter and Ammeter

Voltmeters and ammeters shall be equal or more precision instruments of $10\text{K}\Omega/\text{V}$ and 0.01Ω .

5.2.3 Impedance Meter

Impedance shall be measured by a sinusoidal alternating current method (1kHz LCR meter)

5.3 Standard Charge

Standard charge means charging for 6hours using 29.2V/4A charger

5.4 Standard Discharge

Standard discharge means discharging at 0.2C down to 20V

5.5 Electrical Performance

Item	Condition	Specification
Open-Circuit Voltage	The open-circuit voltage shall be measured within 24hours after standard charge	$\geq 27.2\text{V}$
Battery Capacity	The discharge time at 12A shall be measured after standard charge at $20\pm 5^{\circ}\text{C}$ and rest 30mins	$\geq 100\%$
Charge/Discharge Cycle	The discharge time on standard discharge shall be measured after 1500Cycles of standard charge and discharge at $20\pm 5^{\circ}\text{C}$	$\geq 80\%$
Charge(capacity) retention	The discharge time at 12A shall be measured after standard charge and then storage at $20\pm 5^{\circ}\text{C}$ for 28days	$\geq 80\%$
Temperature Characteristic1	After standard charging at $20\pm 5^{\circ}\text{C}$, laying the battery at 55°C for 4hour, then discharge at 0.2C to 20V, record the discharge time	$\geq 80\%$
Temperature Characteristic2	After standard charging at $20\pm 5^{\circ}\text{C}$, laying the battery at -10°C for 4hour, then discharge at 0.2C to 20V, record the discharge time	$\geq 60\%$

6. Mechanical Performance

Item	Condition	Specification
------	-----------	---------------

6. Mechanical Performance

Item	Condition	Specification
Crush Test	A battery is to be crushed between two flat surfaces. The force for the crushing is to be applied by a hydraulic ram with a 32mm diameter piston. The crushing is to be continued until a pressure reading of 17.2mmPa is reached on the hydraulic ram, applied force of 13kN. Once the maximum pressure has been obtained it is to be released.	No fire, No explosion
Drop Test	The battery has only two axes of symmetry in which case only two directions shall be tested. The battery is to be dropped from a height of 1 meter twice onto concrete ground.	No explosion, No fire, No smoke
Vibration	A full-charged battery is to be subjected to simple harmonic motion with an amplitude of 1.6mm total maximum excursion. The frequency is to be varied at the rate of 1 hertz per minute between 10 and 55 hertz. The cell shall be vibrated for 30 minutes per axis o XYZ axes.	No leakage, No Fire, No explosion

7. Cell Safety Performance

Item	Condition	Specification
Over charge	After normal charge, test the batteries' initial state and capacity. Charge to 20.0V at 3C, then charge at CV mode to 0.01C. Observe battery's variation of appearance	No explosion, No fire
Over discharge	At 20±5°C, the cell are fully charged with standard charging method and standby at least 1hour. The cell should be discharged at a current of 1C for 2.5h.	No explosion, No fire
Short-circuit	At 20±5°C, The cells are fully charged with standard charging method and standby at least 1hour. Positive and negative terminal connect with wire (maximum load of 50mΩ) to cause short circuit until its voltage is lower than 0.1V or cell temperature on the surface is back to room temperature ±10°C.	No explosion, No fire The temperature of the surface of the cell are lower than 150°C
Heating	Battery is heated in a circulating air oven at a rate of 5±2°C per mins to 130°C, an then placed 30 mins at 130°C	No explosion, no fire

8. Delivery Condition

Approx. 50-30% charged

Shipment voltage:24-26.80V

11. Period of Warranty

The period of warranty is one year from the date of shipment. CBE ELETTRONICA guarantees to give a replacement in case of battery with defects proven due to manufacturing process instead of the customer abuse and misuse.

12. Warnings

To prevent the possibility of the battery from leaking, heating, fire, Please READ this specification carefully before usage and observe the following precautions:

- Ⓞ When recharging, use the LiFePO4 battery charger specifically for that purpose
- Ⓞ Do not strike battery with any sharp edge parts, such as Ni-tabs, pins and needles
- Ⓞ Do not immerse the battery in water and seawater
- Ⓞ Do not use and leave the battery near a heat source as fire or heater
- Ⓞ Do not reverse the position and negative terminals
- Ⓞ Do not connect the battery to an electrical outlet
- Ⓞ Do not discard the battery in fire or heat it
- Ⓞ The battery tabs are not so stubborn especially for aluminum tab. Do not bend tab.
- Ⓞ Do not short-circuit the battery by directly connecting the positive and negative terminal with metal object.
- Ⓞ Do not transport and store the battery together with metal objects such as necklaces, hairpins etc.
- Ⓞ Do not directly solder the battery and pierce the battery with a nail or other sharp object.

13. Battery operation instruction

13.1 Charging

Charging current: Do not surpass the biggest charging current which in this specification.

Charging voltage: Do not surpass the highest voltage which in this specification.

Charge temperature: The charge temperature is in according to this specification.

13.2 Discharging

Discharge current: Do not surpass the biggest discharge current which in this specification.

Discharge voltage: Do not be less than the lowest voltage which is in this specification.

Discharge temperature: The discharge temperature is in according to this specification,

13.3 Over-discharges

After the short time excessively discharges charges immediately cannot affect the use, but the long time excessively discharges can cause the battery the performance, battery function losing. The battery long-term has not used, has the possibility to be able to be at because of its automatic flashover characteristic certain excessively discharges the condition, for prevented excessively discharges the occurrence, the battery should maintain the certain electric quantity.

13.4 Storing the Batteries

The battery should store in the product specification book stipulation temperature range. If has surpasses above for six months the long time storage, suggested you should carry on additional charge to the battery.

13.5 Please do not continuously charge the battery over 8hours.